

# An Advanced Method and Circuit for RLC Shaping of NaI(Tl) Scintillation Detector Signals

George Mitev Mitev, Mityo Georgiev Mitev and Ludmil Todorov Tsankov

**Abstract** - In this article is described an advanced method and a schematic for RLC shaping of NaI(Tl) scintillation detector signals, whose utilization allows for overcoming the limitation, posed by the maximum resonance frequency of the shaping LC circuit and thus decreases the dead time for transformation. This simple method can be used for shaping and conversion at higher pulse rates.

**Keywords** – RLC Shaping, NaI(Tl) Scintillation Detectors

## I. INTRODUCTION

### A. Basic information for the scintillation detectors

The large variety of scintillators, as well as the high sensitivity and the good stability of the modern photoelectron multipliers (PMTs) explain the wide use of scintillation detectors for registration of ionized emission parameters. In order to achieve high sensitivity, good energy resolution and high response time, it is necessary [1]: to reach full collection of the charge, formed in the PMT anode circuit; to have a linear relation between the charge and the amplitude of the output pulse in the widest possible dynamic range; and also to be able to quickly restore the shaping RC circuit.

### B. LC shaping of the PMT signal

Adding an inductance to the anode circuit of the PMT makes worse the pulse forming conditions, creating continuous damping oscillations. That is why precautions must be taken to ensure the parasitic inductances would be minimized.

At the end of the 60s and the beginning of the 70s have been used schematic solutions, in which the output pulses of the PMT excite damping oscillations in an LC circuit [2], [3], [4], [5]. By means of an amplitude discriminator those oscillations are being transformed into a package of rectangular pulses. It is easy to show that their number is proportional to the  $\ln(E)$  -  $E$  being the energy of the particle, registered in the detector.

### C. Specifics of the LC shaping

The initial amplitude of the damping oscillations during the LC shaping depends on the charge, excited in the anode circuit of the PMT, respectively on the energy of the

registered emission. Thus, it is possible, using simple schematic techniques, to realize a multi-channel amplitude discriminator [6], [7], which could be the base of a multi-channel spectral analyzer [8]. A characteristic feature for the accumulated specters is the logarithmic energy scale. A disadvantage is the long dead time of the converter, which limits the application of the method in the study of low intensity emissions only.

### D. Goals and tasks

The goal of this study is the decrease of the dead time of the resonance converters and also to achieve lower differential “non-logarithmicity” and register the spectrogram in higher number of channels.

For that to be achieved, it's necessary to fulfill the following tasks:

1. Find a schematic solution, which guarantees full collection of the formed charge, and afterwards configure an oscillation contour, in which to be stimulated freely damping oscillations.
2. Ensure optimal reading of the oscillation circuit signal with an option for regulation of the oscillations' damping time.
3. Synthesize a bipolar amplitude analyzer, guaranteeing parity of the discrimination thresholds of the positive and negative signals.

## II. PRESENTATION

In order to get a reasonable decrease in the dead time, it is necessary to increase the resonance frequency of the shaping LC circuit. A limitation to the full charge collection (on which depends the definitiveness of the transformation function) is the period of the excited oscillations in the oscillation circuit to be longer than, at least 10-12 times the decay time of the scintillator. This limitation cannot be overcome when using an LC shaping, while the anode current of the PMT is being dynamically split between the L and the C. That is why in this solution it is defined that the charge, generated in the anode circuit of the PMT, will be accumulated in the shaping capacitor, and after a time period 5 times longer than the decay time of the scintillator, a suitable inductance should be connected to the capacitor. In this way the resonance frequency of the oscillating circuit is not linked to the decay time of the scintillator and could be chosen to be relatively higher. Thus the dead time of the shaper would be vastly reduced.

An analogue switch is needed, in order to configure the oscillating circuit at a given moment, to connect the inductance to the shaping capacitor. The requirements for that switch are very high. It should have very high resistance when switched on, small stray capacitance, when switched off, and a very low level of the charge transferred from the control circuit to the commutation circuit.

---

G. Mitev is with the Institute for Nuclear Research and Nuclear Energy, Nuclear Electronics Laboratory, Bulgarian Academy of Sciences, Blv. Tzarigradsko Shausse 72, 1784 Sofia, Bulgaria, e-mail: [g\\_m\\_mitev@yahoo.com](mailto:g_m_mitev@yahoo.com)

M. Mitev is with the Department of Electronics and Electronics Technologies, Faculty of Electronic Engineering and Technologies, Technical University - Sofia, 8 Kliment Ohridski blvd., 1000 Sofia, Bulgaria, e-mail: [mitev@ecad.tu-sofia.bg](mailto:mitev@ecad.tu-sofia.bg)

L. Tsankov is with the Department of Nuclear Engineering, Sofia University, 5, J.Bouchier blvd, BG-1164 Sofia, Bulgaria, e-mail: [ludmil@phys.uni-sofia.bg](mailto:ludmil@phys.uni-sofia.bg)

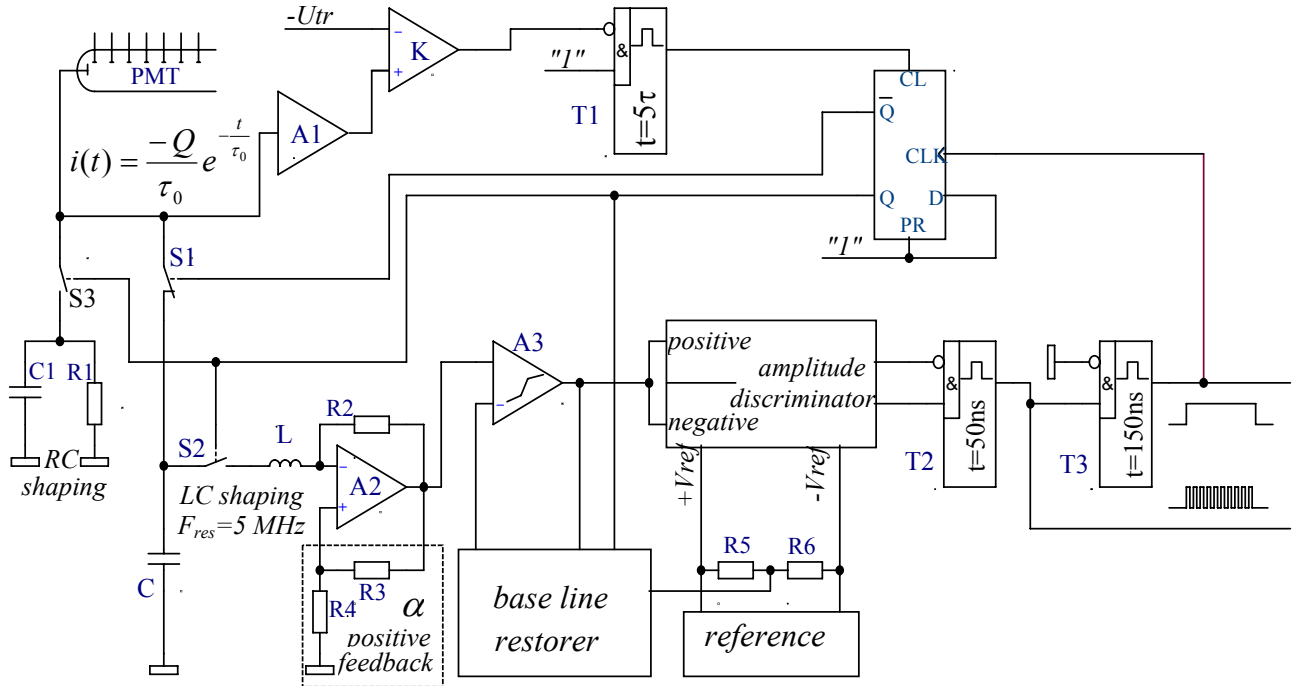

Fig. 1

The block diagram of the LC shaper with improved parameters, containing the beforementioned principles, is shown on Figure 1.

The main components in the schematic are the analogue switches S1, S2 и S3. With their help the anode circuit of the PMT is connected either to the shaping capacitor (in LC shaping mode), or to the RC circuit (for shaping of the pulses that were allowed to pass through, during the conversion), as well as for forming of an oscillator circuit.

The linear channel includes the buffer amplifier A1 and the comparator K. The threshold level  $-U_{tr}$  is chosen based on the lowest energy of the gamma quanta, which are going to be registered. The full collection of the charge in the anode circuit of the PMT is guaranteed by the timer T1, set to a time-delay exceeding 5 times the decay time of the scintillator. When using NaI(Tl) crystals this time is chosen to be in the range of 1.5  $\mu$ s for work in laboratory environment and over 3.5  $\mu$ s for on-field measurements. This is implied by the fact that for a decrease of the surrounding temperature down to  $-30^{\circ}\text{C}$  the decay time of the scintillator gets increased to 700 ns.

After the time for full charge collection runs out, the circuit is switched to conversion mode, S1 gets open, and S2 and S3 get closed. If during the conversion, new  $\gamma$ -quanta get registered, the newly formed current pulses in the anode circuit of the PMT will be shaped by R1C1. They can be registered in a linear channel (at the output of the linear amplifier A1), or get counted as missed events (at the output of the comparator K).

S2 connects the inductance L to the charged capacitor C, configuring this way a resonance oscillating circuit. Part of this circuit is also the amplifier A2, which is realized as a trans-impedance amplifier with a very low input resistance. The schematic of this amplifier is shown on Figure 2. A CFA of type AD844 has been used because of the wide dynamic range of the output amplitude it could cover. As an analogue switch is used ADG451, which has a  $4\Omega$

resistance of the switched-on channel and a dynamic range of the switched signal  $\pm 15\text{V}$ . Another parameter of the analogue switch, which is of essential importance for the present application, is the charge that is transferred from the control circuit to the commutation circuit (charge injection) and for ADG451 it is 20 pC.

The time diagrams showing the form of the anode current of the PMT, the voltage on the accumulation capacitor and the voltage at the output of the input amplifier are shown on Figure 3. The moment when the circuit switches into conversion mode and in the resonance circuit arise freely damping oscillations, is clearly visible. To make the time diagrams easier to read, additional losses have been introduced to the oscillation circuit.

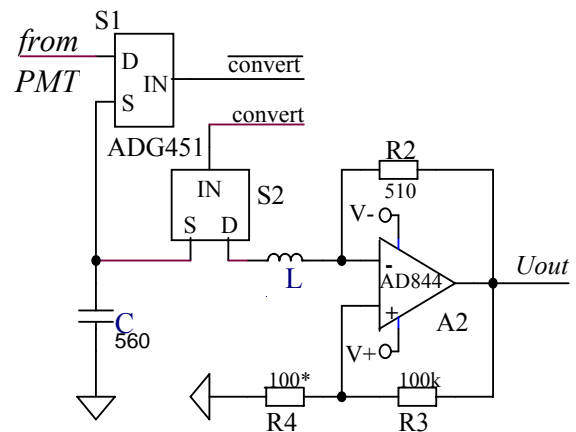

Fig. 2

From the supplied results is clear that the proposed method guarantees full collection of the charge formed in the anode circuit. The schematic functions are stably at a higher resonance frequency – in this case it is 5 MHz, which leads to shorter conversion time. At the beginning of the charging process of the accumulation capacitor arise damping oscillations with a very low amplitude and a few

times higher frequency. They are a result of the parasitic oscillation circuit, formed by the inductance of the accumulation capacitor and the serially connected stray capacitance of the open analogue switch, which doesn't affect the work of the converter. The number of the channels, in which the spectrogram gets registered, depends mainly on the quality factor of the oscillation circuit. For the configured resonance system, a noticeable influence has the active resistance of the used analogue switch, when turned-on, which leads to an increase in the losses of the circuit. An effective "increase" of the quality factor might be achieved by decreasing the losses in the circuit, or by compensating them through restoring energy, less than the real physical losses, back to the circuit [6].

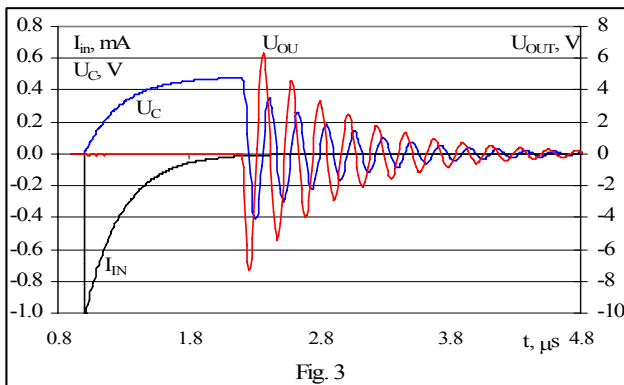

Fig. 3

At first look, for the proposed schematic of the input amplifier this could not be realized, because the output voltage of the amplifier repeats the form of the current in the resonance circuit – i.e. it is shifted with  $\pi/2$  from the voltage in the circuit. In practice the introduction of a small positive feedback  $\alpha=R_4/R_3$  in the input amplifier would lead to a partial compensation of the losses in the circuit. On Figure 4 is shown the output signal of the amplifier at different level of the positive feedback. It can be seen that for the same initial conditions the amplitude of the freely damping oscillations is different. This allows for the

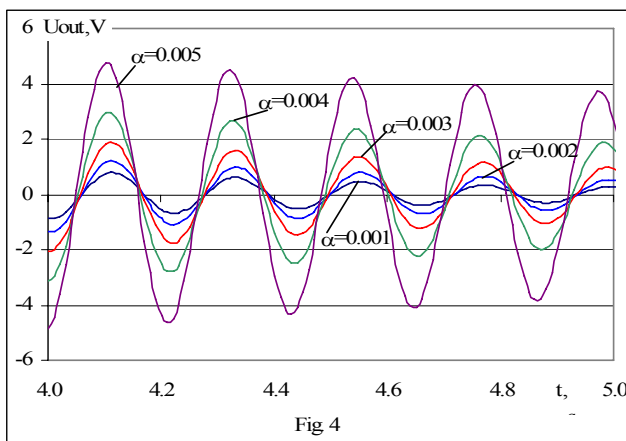

Fig. 4

spectrogram to get registered in a larger number of channels. The easy regulation of the level of feedback (through change in the relation of two resistors) makes possible the precise selection and tuning of the energy-channel dependence.

In order to get a larger number of channels, in which to register the events, of higher importance is the discrimination threshold of the amplitude discriminator, than the initial amplitude of the excited oscillations,

corresponding to the highest energy emission. Some limitations exist to the aspirations for decrease of this threshold, connected to the stability, noise resistance etc. This implied the necessity of the introduction of a restrictive amplifier A3, which could amplify the signals with low amplitude, and let pass through those with higher amplitude without a change. Thus is achieved an effect of lowering the discrimination threshold of the amplitude discriminator.

Having in mind that the freely damping oscillations of the oscillating circuit don't have a DC component, we might show that the amplitude of the positive and of the negative half-waves is lowered with the same value, but with an opposite sign. If the damping oscillations are fed to an amplitude discriminator, that could separate bi-polar signals in reference to the same (as absolute value) threshold, then the number of the discrimination levels would have doubled. This could be achieved through two integral amplitude discriminators, which discrimination thresholds are equal as absolute values, but are with different signs.

In order to ensure good results when applying this approach, it is necessary to provide a very good correlation of the zero lines between the two discrimination thresholds and the output of the restrictive amplifier. The differential nonlinearity of the circuit, as well as the stability of the converter's work, depends on this correlation. It could be achieved by the introduction of a base-line restorer (BLR). The circuit monitors for a deviation of the signal at the output of the amplifier from the average value between the two discrimination thresholds, and minimizes it through a negative feedback. When in conversion mode the feedback is broken and the DC mode of the amplifier is kept identical to the one supported immediately before the conversion. For the short time during conversion, the conditions influencing the DC modes cannot change.

The block diagram of the nonlinear amplifier, the bipolar amplitude discriminator and the base line restorer is shown on Figure 5.

The non-linear amplifier is realized with AD8038, in a way that, when reaching output levels higher than  $\pm 200$  mV, the Schottky diode BAT54S switches on to conducting state and the gain gets highly reduced. In the amplitude discriminator are used precise fast comparators AD790.

As a reference voltage source is used the parallel stabilizer TL431. The bipolar threshold voltage is generated by an amplifier with -1 gain, realized with a precise operational amplifier AD822. The schematic allows for setting both discrimination thresholds  $+V_{ref}$  and  $-V_{ref}$  to the same value.

The base line restorer is built around an Operational Transconductance Amplifier (OTA) of type CA3080. During the conversion the current flow, setting the work state of the input differential subcircuit is cut and the compensation of the offset voltage of A3 is kept constant by the last value stored in the capacitor  $C_K$ .

### III. DISCUSSION

The proposed schematic solution, using a switching of the shaping circuit at the anode of the PMT of the scintillation detector, guarantees full collection of the generated charge and reaching higher resonance frequency, compared to the limitations posed by the direct LC shaping.

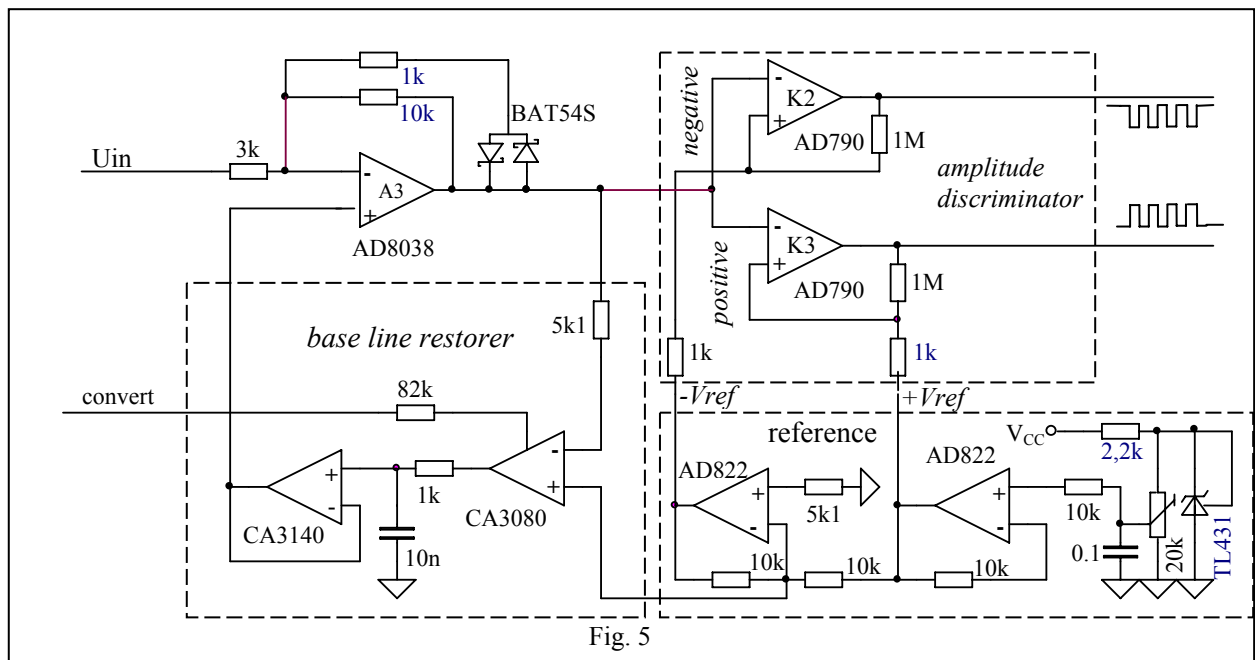

Fig. 5

The introduction of a bipolar amplitude discriminator and a base line restorer for the last amplifier before the discriminator makes possible the work with low discrimination thresholds, while keeping excellent differential non-linearity.

All of the described changes allow for the acceleration of the convertor's work, also help for the decrease of the dead time, improve the differential nonlinearity, and make possible the increase of the number of channels, in which the registered gamma-quanta are distributed, according to their energy.

#### IV. CONCLUSION

The applied method for reconfiguration of the C-CL shaping circuit, used for the reading of the scintillation detector signals, helps for the increase of the resonance frequency above the critical value for this type of converters. Thus, the conversion time is shortened and might reach values comparable to those, characteristic for the Wilkinson converters, while achieving a logarithmic relation between the energy and the channel number.

#### V. ACKNOWLEDGEMENT

This work is supported by the Bulgarian National Science Fund under contracts BYH3 - 01/06.

#### VI. REFERENCES.

- [1] Wright, A.G. *Amplifiers for use with photomultipliers – who needs them?*. Nuclear Instruments and Methods in Physics Research A 504 (2003) 245-249.
- [2] Barton, J.C., A. Cripin. *Simple logarithmic pulse height analysers*. Nuclear Instruments and Methods, 16 (1962) 39-43.
- [3] Гадалов, А., Ю. Минеев, И. Рапопорт, *Логарифмический амплитудно-числовой преобразователь на колебательном контуре с демпфирующим устройством*. ПТЕ №5 1966г., стр.144-146

- [4] Степанов, В., *Логарифмический преобразователь амплитуды импульсов*. ПТЕ №3 1969 г., стр. 115-118
- [5] Barton, J.C., A.F.Munas, A.G.Wright. *Improved Ringing Coil Pulse Encoders*. Nuclear Instruments and Methods, 92 (1971) 89-91.
- [6] Mitev, M., Ch.Lenev. *Charge to Digital Logarithmic Resonance Converter*. Proceedings of the National Scientific Conference "Electronics '99", book III, pp 28-33, 1999.
- [7] Mitev, M.G., T.B.Lenev, L.T. Tsankov. *An Improved Resonant Charge-Code Transducer*, Proceedings of the Tenth International Scientific and Applied Science Conference "Electronics ET'2001", book 1, pp 111-124, 2001.
- [8] Mitev, M., L.Tsankov, Ch.Lenev. *A Spectral Analyser With a Logarithmic Energy-Code Characteristic - Nature, Features, Advantages and Drawbacks*. Proceedings of the 12 International Scientific and Applied Science Conference "Electronics ET'2003", book 2, pp 30-35, 2003.
- [9] Tsankov L, M.Mitev, Ch.Lenev. *LC circuit as a pulse-height analyser for NaI gamma spectrometry*. Nuclear Instruments and Methods in Physics Research A 533 (2004) 509-515
- [10] Mitev M., L.T. Tsankov, *Optimization of a RLC shaping circuit for NaI(Tl) scintillation detectors*. Proceedings of the 14 International Scientific and Applied Science Conference "Electronics ET'2005", book 2, p-p 199 – 204, 2005.